

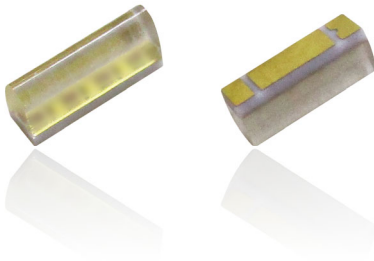

PART NO. : EOS-101U400A00



Slim LED

4313-4S Series- Red Color

Data Sheet

Features

- AllnGaP chip technology
- Slim linear LED lighting device
- Pb free and RoHS compliant product
- MSL 2a
- ESD up to 8kV (HBM)
- AEC-Q102 certified

Applications

- Automotive application
- Indicator / decoration

Outline Drawing

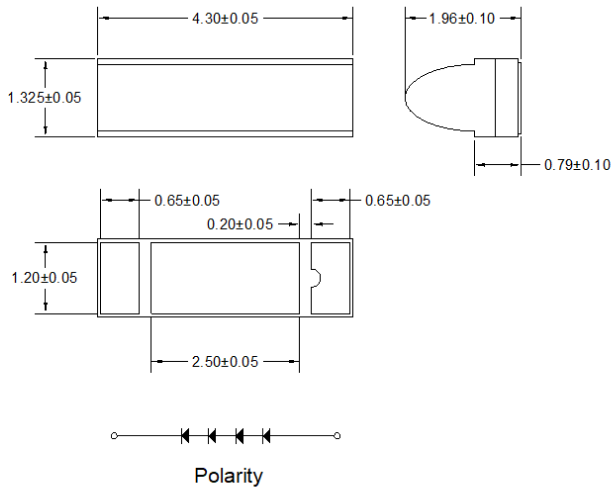

Beam Pattern

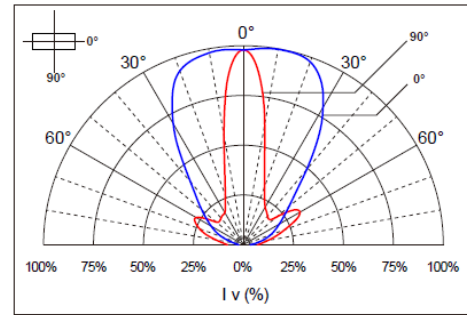

Recommended Soldering Pad

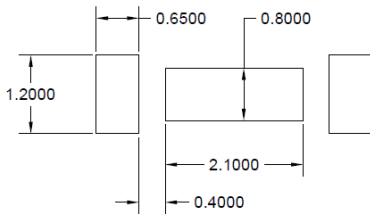

Note:

1. All dimensions are in millimeter.
2. Tolerance is ± 0.10 mm unless otherwise noted.
3. Specifications are subject to change without notice.

Absolute Maximum Ratings at $T_A=25^\circ\text{C}$

Parameter	Symbol	Max.	Unit
Average Forward Current ^[1]	I_F	70	mA
Peak Forward Current ^[2]	I_{peak}	150	mA
Reverse Voltage ^[3]	V_R	5 (Not designed for reverse operation)	V
Power Dissipation	P_D	0.70	Watt
LED Junction Temperature	T_J	150	$^\circ\text{C}$
Operating Temperature Range ^[1]	T_{OPR}	-40 ~ 125	$^\circ\text{C}$
Storage Temperature Range	T_{STO}	-40 ~ 125	$^\circ\text{C}$
Thermal Resistance (Junction / Soldering Point) ^[4]	$R_{\theta JS}$	10 (Typ.)	K/W
Lead Soldering Condition (Reflow)	T_{SOL}	Below 260°C , Max. 10 seconds	

Note: [1] Design of heat dissipation should be considered. For the allowable operating current at different operating temperature, please refer to fig 4. page 4.

[2] Duty ratio=1/10, pulse width=0.1ms.

[3] This device is not designed for reverse voltage application. The reverse voltage or current may damage LED.

[4] This value is taken from a statistical sampling, and is provided for reference only. It's recommended to build in a safety margin for the design of heat dissipation, to ensure LEDs perform normally and optimally.

Ordering Information

Ordering Code	Total Flux $\Phi_v(\text{lm}) @ I_F=50\text{mA}$		Dominant Wavelength $\lambda_D(\text{nm}) @ I_F=50\text{mA}$		Forward Voltage $V_F(\text{V}) @ I_F=50\text{mA}$	
	Min.	Max.	Min.	Max.	Min.	Max.
EOS-101U400A00-P001	17.5	25	627	639	7.5	10

Device Selection Guide (Electrical and Optical Characteristics at $T_A=25^\circ\text{C}$)

Part Number EOS-	Driving Current $I_F(\text{mA})$	Total Flux $\Phi_v(\text{lm})$		Dominant Wavelength $\lambda_D(\text{nm})$	Forward Voltage $V_F(\text{V})$		$I_R(\mu\text{A})$ @ $V_R=5\text{V}$
		Min.	Typ.	Typ.	Typ.	Max.	Max.
101U400A00	50	17.5	22	630	8.8	10	10 (Not designed for reverse operation)

Luminous Flux Bin Rank

Total Flux Bin Rank $\Phi_v(\text{lm}) @ I_F=50\text{mA}$		
Min.	Max.	Bin Rank
17.5	20	5L
20	22.5	XM
22.5	25	YM

Note: 1. Measurement uncertainty of luminous flux: $\pm 10\%$.

Dominant Wavelength Bin Rank

Dominant Wavelength $\lambda_D(\text{nm}) @ I_F=50\text{mA}$		
Min.	Max.	Bin Rank
627	639	UA

Note: 1. Measurement uncertainty of dominant wavelength: $\pm 1.0\text{nm}$.

2. Measurement uncertainty of forward voltage: $\pm 0.1\text{V}$

Forward Voltage Bin Rank

Forward Voltage $V_F(\text{V}) @ I_F=50\text{mA}$		
Min.	Max.	Bin Rank
7.5	8.0	A
8.0	8.5	B
8.5	9.0	C
9.0	9.5	D
9.5	10.0	E

Typical Electrical / Optical Characteristic Curves

(25°C Ambient Temperature Unless Otherwise Noted)

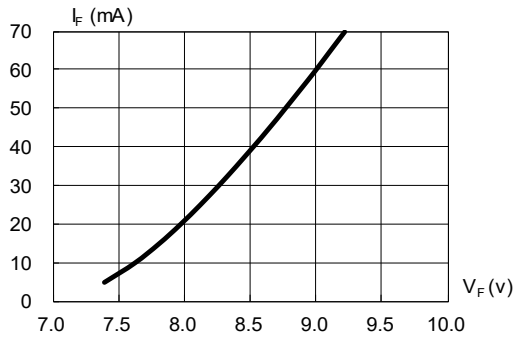

Fig.1 Forward Current vs. Forward Voltage

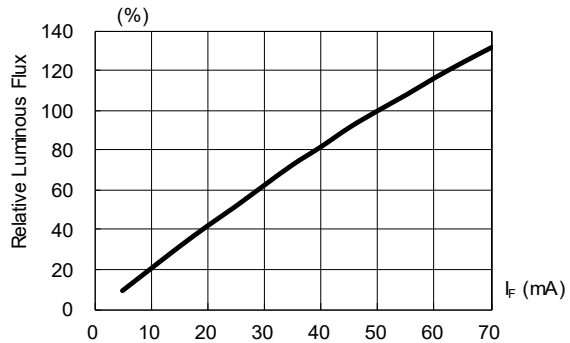

Fig.2 Luminous Flux vs. Forward Current

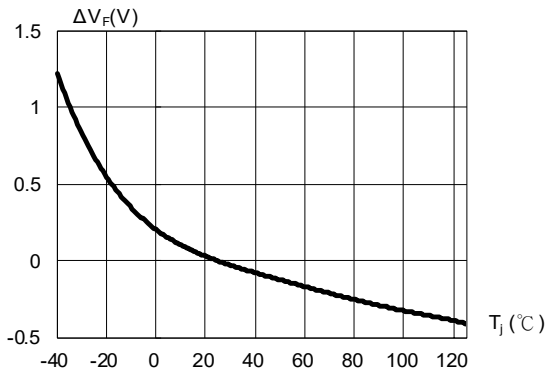

Fig. 3 Relative Forward Voltage vs. Junction Point Temperature
 $\Delta V_F = V_F - V_F(25^\circ C) = f(T_s)$; I_F = 50mA

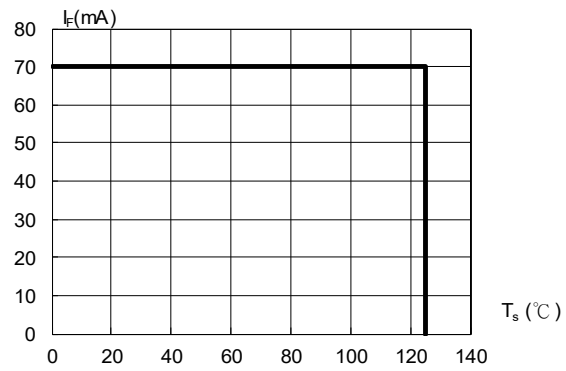

Fig.4 Allowable Forward Current vs. Solder Point Temperature

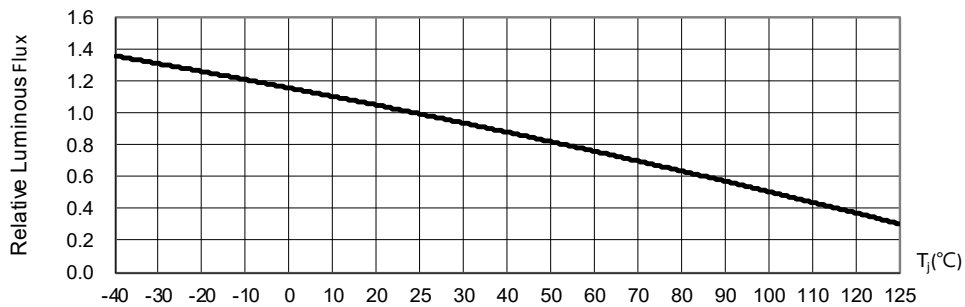

Fig. 5 Luminous Flux at I_F=50mA vs. Junction Point Temperature

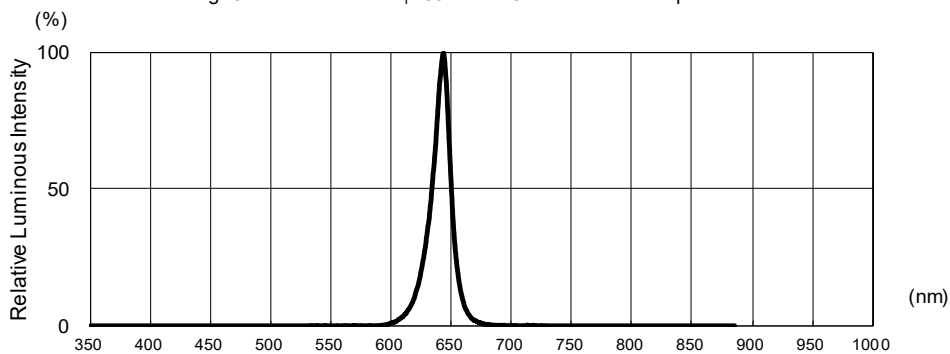
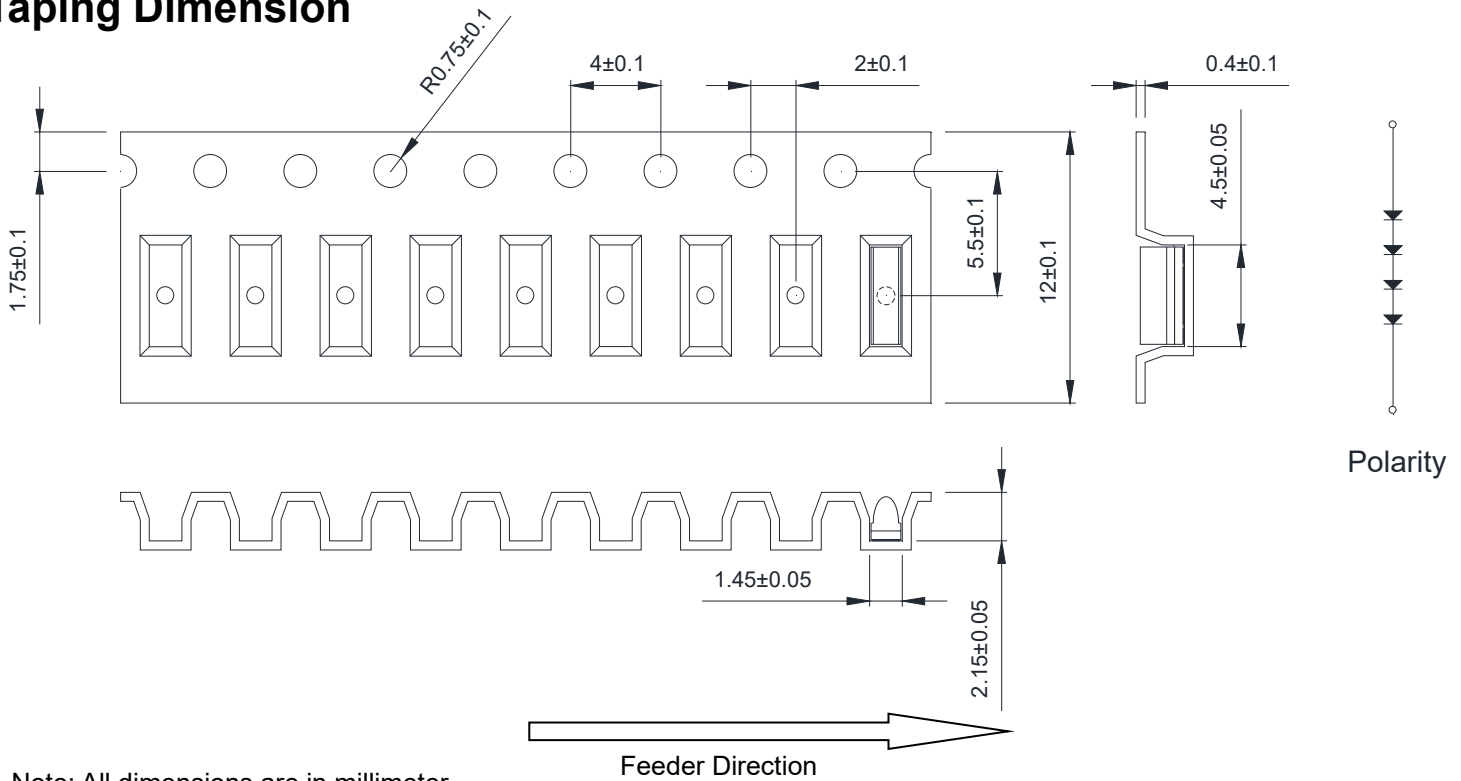

Fig.6. Relative Luminous Intensity vs. Wavelength

Note: The data shown above are typical values, which do not correspond to the actual parameters of every single LED. These figures can only reflect statistical curves, and the typical data will be changed without further notice.

Taping Dimension



Note: All dimensions are in millimeter.

Shipment Package

Every reel is packaged in the aluminum moisture barrier anti-static bag (specific bag material will depend upon customer's requirement or option), and every bag is well sealed before shipment.

For moisture protection, silica gel material is also packed in each bag and a humidity indicator card inside the bag acts as an indicator, which alerts users to the humidity within the package bag by change of color.

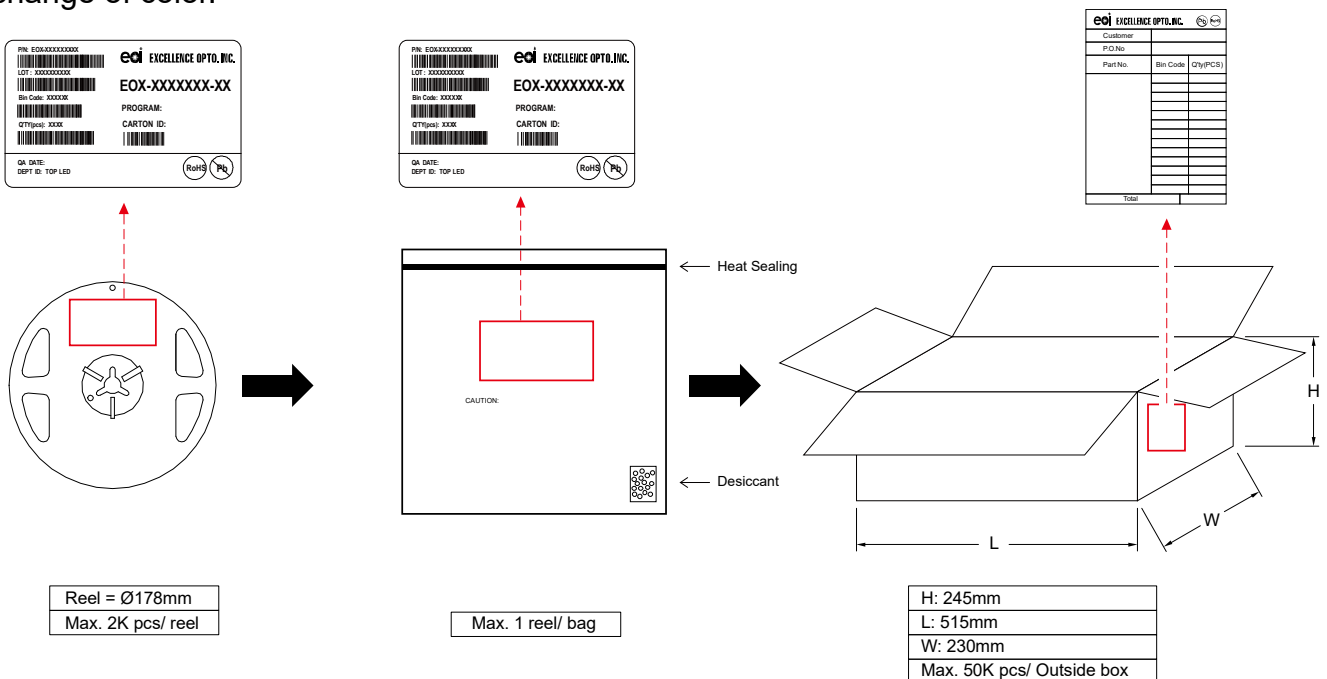

Description of Bin Code

EOI's LEDs are tested and sorted into different bins with individual bin code. The LED bin code is shown on the label of every shipment package, and includes the information of color, brightness, and also forward voltage of LED. Please refer to the rank combination of every product to get detail information of each bin code.

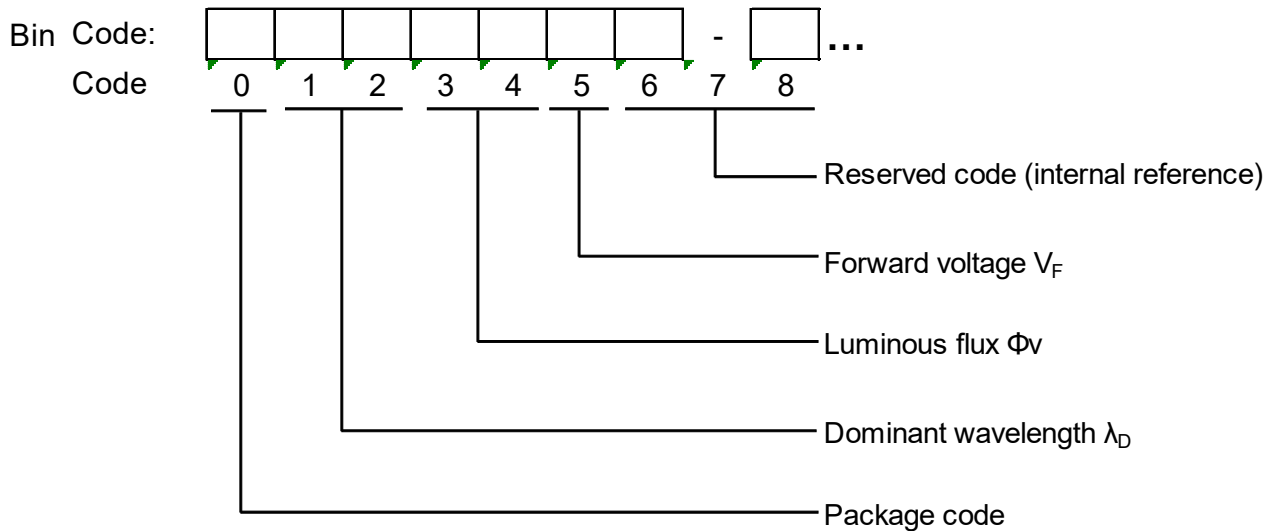

Precaution of Application

1. Circuit layout and design

- (1) Due to the forward voltage of LED will vary with temperature and its driving current, the current-limited protective circuit should be considered in the LED circuit design.

When LEDs are arrayed as a parallel circuit, different inherent resistance of LEDs will cause unbalance current. The unbalanced driving current which exists in every parallel circuit may make LED be driven at different power. Therefore, the LED driven at higher power may be damaged by over driving current, and the LED driven at lower power may be dimmer than the others.

To solve this situation, a suitable resistor is recommended to put in series with each LED circuit. The resistor will limit and balance the driving current which flows through every parallel circuit.

- (2) For circuit design, the current through each LED must not exceed its Absolute Maximum Rating.
- (3) LEDs should be operated in forwarding bias. A driving circuit must be designed well so that neither forward nor reverse voltage would be applied to LEDs while powered off. Without such correct circuit design, damage may occur to LEDs, especially if a reverse voltage is continuously applied to LEDs.

2. Electric Static Discharge (ESD) Protection

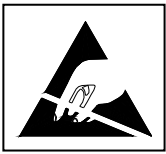

All LED materials, such as GaP, AlGaAs, AlInGaP, GaN, or InGaN chips, are STATIC SENSITIVE devices. ESD protection or surge voltages shall be considered and taken care of in the whole product design and production process.

The following protection is recommended:

- (1) A wrist band or an anti-electrostatic glove shall be used when handling the LEDs.
- (2) All devices, equipment, and machinery must be properly grounded. The whole environment of processing and manufacturing should be controlled and kept at a suitable ESD protection level.
- (3) It is recommended to perform electrical tests to screen out ESD failures at final inspection.
- (4) It is important to eliminate the possibility of surge current during circuitry design.

If LED is damaged by ESD or surge voltage, the damaged LED may show some unusual characteristics, such as leakage current, dimmer, or no light emission. When a damaged LED is inspected at a low driving current, black dots may appear within the emitting area.

3. Storage

Slim LED devices are MOISTURE SENSITIVE. Please protect LEDs from moisture all the time, including transportation and storage.

It's recommended to store the products in the following conditions:

- (1) Shelf life in original sealed bag: 12 months at $T_A < 40^\circ\text{C}$ and Hum. $< 60\% \text{RH}$. (Based on aluminum laminated moisture barrier bag.) Baking may be required when the shelf life is expired.
- (2) Before opening the bag, please check the bag is well sealed and intact.

- (3) After opening the original sealed bag, please check the humidity indicator card first. If the color on the circles of 5% and 10% turns pink, it indicates that the reel of LED needs to be baked. If the color of the 15% circle turns pink, please contact our sales to get further instructions.
- (4) After the sealed bag is opened, the LED must be kept in the following environment:
Humidity (Hum.): < 60%RH
Temperature (T_A): 5°C ~ 30°C
Assembly duration (subject to reflow): please refer to MSL conditions.

It's recommended to complete LED assembly (subject to reflow) as soon as possible after the bag is opened.
- (5) If some LEDs are not used after the bag is opened, please keep unused LEDs with moisture absorbent material in moisture-proof sealed bags or airtight containers. When these unused LEDs will be used again, pre-qualification should be done before production.
- (6) Please avoid rapid transitions in ambient temperature, especially in a high humidity environment where condensation can occur.
- (7) The surface condition of leads and pads of LED is sensitive to corrosive materials. When LED is exposed to a corrosive environment, it may cause the plated metal parts of LED to be tarnished, which would adversely affect its soldering and optical characteristics.

4. Pick and Place

Since the silicone lens is a soft material, please do not press mechanical stress on the surface of the silicone lens or stack the LEDs together, it may cause the LEDs failure.

Special attention should be paid during the assembly process:

- (1) It should be avoided to load stress on the silicone lens during the pick and place process, especially at high temperatures.
- (2) It's recommended to choose a suitable nozzle to pick up the SMD products during the process of SMT production. The inner diameter or size of the nozzle should be taken care of to make sure that the lens of the LED will not be touched or pressed by the nozzle.
- (3) Avoid rubbing or scraping the resin by any object, and avoid leaving fingerprints on the lens.
- (4) Electric-static may cause damage to the component. Please ensure all equipment is

grounded well.

- (5) Some parts of Slim LED are using silicone material as encapsulation material. The silicone material is easily contaminated by particles. However, a small number of particles on the LEDs will not affect the brightness of the LEDs, and also the lifetime. Therefore, a small number of particles on the surface of the lens of LEDs will not affect the performance.
- (6) Figure 1 shows the recommended pick and place nozzle designs.

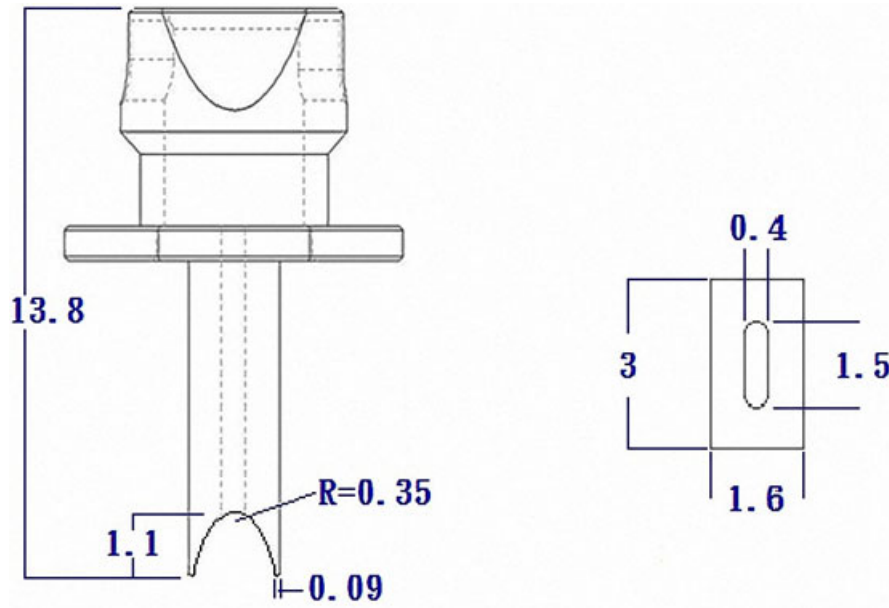

Note: All dimensions are in millimeters.

Figure.1

5. Handling Precautions

Since the silicone lens is a soft material, please do not press mechanical stress on the surface of the silicone lens or stack the LEDs together, it may cause the LEDs failure.

- (1) It is forbidden to touch the LED with bare hands since the surface may be contaminated and affect the optical characteristics when handling the product. The LED may be deformed and the die/wire bond be broken by the excessive force on the LED and then cause the LEDs not to illuminate.
- (2) Do not use tweezers for manual operations to avoid mechanical force causing damage to the LED, please use a vacuum pen for manual operation. For manual operation with a vacuum pen, always pick up from the top of the silicone lens and never from the sides of the silicone lens. The suction nozzle should be made of a soft material such as rubber to drop the

mechanical force exerted onto the silicone lens.

(3) Figure 3 shows the suction nozzle used in Figure 2, and the material is rubber.

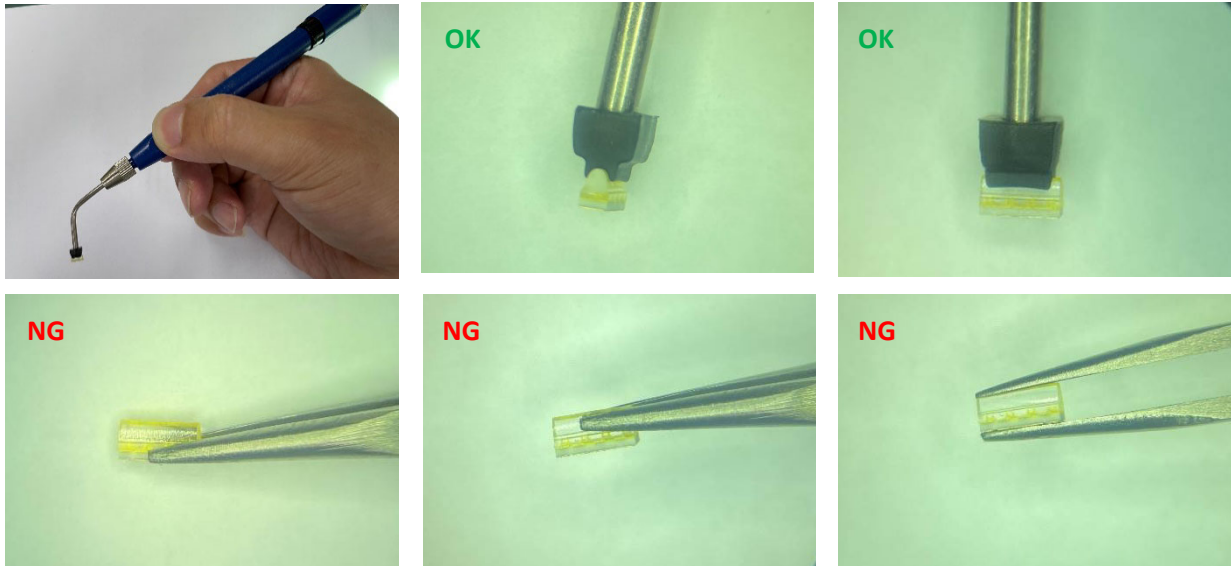
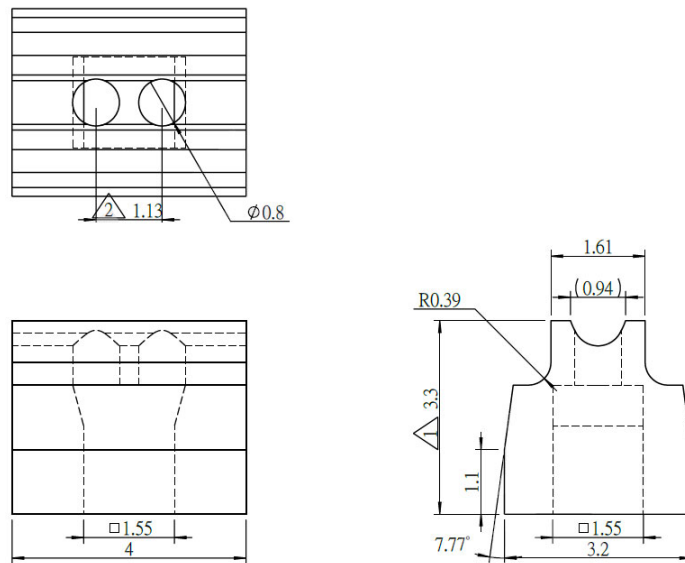

Figure.2



Note: All dimensions are in millimeters.

Figure.3

6. Reflow Soldering

To prevent LED from cracking in the reflow process, it's better to bake LED components before reflow soldering. After the package sealing bag is opened, please use the LED device as soon as possible to keep the LED from moisture.

It's banned to load any stress on the silicone lens during soldering. Never take the next process until the component is cooled down to room temperature after reflow. And, the manual soldering process is not recommended for quality consideration.

To ensure the performance of the LED device, it is recommended to set up a reflow profile at a lower temperature, and reflow soldering should not be done more than one time.

The recommended reflow soldering profile (measure point is near the bottom of the LED package) is following:

Recommended Pb-free Soldering Profile

(Reference : IPC/JEDEC J-STD-020D)

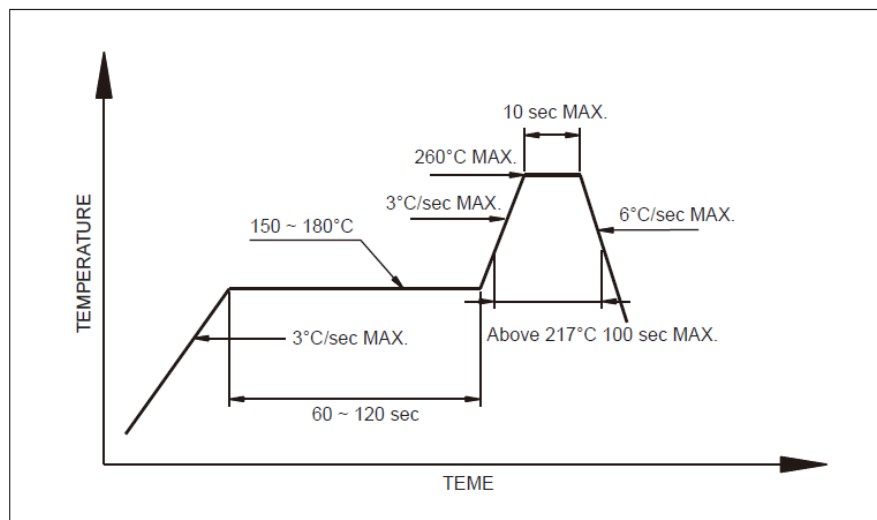

The soldering paste should be coated to the necessary area of soldering pads by the screen-printing or with the dispenser. In the case of the screen-printing, it is recommended to have a thickness of 0.1mm to 0.2mm. The optimal thickness should be verified by pre-test and will be different from every different layout of leads of the LED.

Repairing should not be done after the LEDs have been soldered.

7. Thermal Management

Please design products in order to prevent the LED chip temperature from exceeding the maximum Junction Temperature (T_j). When designing a product, the T_j can be lowered by implementing methods to lower the thermal resistance of the product.

(1) Optimization of the copper foil area of the board:

To transfer the heat generated by the chip to the board as much as possible, it is recommended to increase the thermal conductive area by increasing the area of the copper foil.

(2) Optimization of the LED placement (LED pitch):

If the LED pitch becomes too narrow, it will be harder to radiate the heat generated in a concentrated area. By increasing the LED pitch as much as possible, the T_j could be lowered.

(3) Implementing heat sinks:

The heat radiation efficiency can be improved by attaching a heat sink to the backside of the board.

8. Others

(1) The strong light from LEDs may injure human eyes. Precautions should be taken to prevent looking directly at the LEDs with unaided eyes.

(2) LED device is very sensitive to heat. In order to get maximum light output during the duration of LED's long life, the designer should consider the best methods and design for thermal dissipation when designing the entire system. It's recommended to avoid intense heat generation and to operate within the maximum ratings given in this specification.

(3) Every piece of LED will be sorted and LEDs with the same binning grade will be taped into the same reel or put into the same bag. It is recommended to use the same bin-grade LED to assemble the unit module. This will ensure the LED unit module with good uniformity of brightness, hue, and so on.

(4) For outdoor usage, the necessary measure should be taken to prevent the damage from water, moisture, and salt spray.

(5) Do not use sulfur-containing materials in commercial products.

Terms and Condition

1. EOI warrants all sold LEDs which conform to the specifications approved by the customers.
2. Any LED supplied by EOI is found not conform to the specifications that both parties agreed upon, customer should claim within 30 days of receipt.
3. EOI will not hold any responsibility for the failed LEDs, which are caused by mishandling or misusing the LEDs exceeding the operating conditions that EOI suggested.
4. EOI's LED products are designed and manufactured for general electronic equipment (such as household appliances, communication equipment, office equipment, electronic instrumentation and so on). If customer's application requires exceptional quality or reliability, which might concern human safety, it is necessary to consult with EOI in advance.
5. All the information published is considered to be reliable. However, EOI does not assume any liability arising out of the application or use of any product described herein. EOI's liability for defective LED lamps shall only be limited to replacement, in no event shall EOI be liable for consequential damages or loss.
6. EOI and customer shall both confirm the specifications herein, and all quality related matters will base on the specifications both parties agreed upon.
7. The information in this documentation is subject to change without notice.

© All rights reserved. Product specifications are subject to change without notice.



**Headquarters
Excellence Opto. Inc.**

No.2, Kedong 1st Road, Chunan Town, Miaoli County, Hsinchu Science Park, Taiwan 35053, R.O.C.
Tel: 886-37-539000 Fax: 886-37-586789
E-mail: Service@eoi.com.tw
http://www.eoi.com.tw

**U.S. Company
Excellence Opto. Inc.**

1663 West 2nd Street, Pomona, CA 91766, U.S.A.
Tel: 909-784-3333 Fax: 909-784-3330
E-mail: Sales@eoius.com
http://www.eoius.com

**China Subsidiary I
Excellence Opto. (DongGuan) Ltd.**

No. 33, HaiBin Road, Wusha Community, Chang-An Town, DongGuan City, P.R.O.C.
Tel: 86-769-89236999 Fax: 86-769-89236688

**China Subsidiary II
Lianxinfeng Opto. Co., Ltd. (LXF)**

1~3/F, Building 5, AoHua Industrial Park, No. 148, HuaRong Road, GaoFeng Community, DaLang Office, LongHua, ShenZhen City, GuangDong Province, P.R.O.C.
Tel: 86-755-28140029 Fax: 86-755-28140027
http://www.eoi-lxf.com